

Foundry Flow Studies Based on Water Model Gating System

Research Article

P. Sivaraman¹, T. Nithyanandhan¹, MK. Prabhu¹, B. Prasanna², G. Murali Krishna², S. Prassana Kumar², S N Kishore²

¹ Assistant Professor, Mechanical Engineering, SKCT Coimbatore, India.

² UG Students, Mechanical Engineering, SKCT Coimbatore, India.

Abstract

During late years, foundry industry has seen an expanding mindfulness about the significance of the filling stage for the creation of metallurgical stable and dimensionally stable castings. Specifically, oxide as well as gas entanglement into the greater part of the liquid metal during the filling of shape hole can cause shocking bringing down of the mechanical properties of the throwing, particularly during throwing of those combinations inclined to frame oxides in contact with air, for example, light composites or malleable iron. This could thusly be damaging to the "wellbeing" of the throwing during its presentation under the forced assistance conditions. In this way, much consideration is centered around understanding the methods for limiting or taking out the ensnarement of stages which are exogenous to the dissolve, for example, oxides and air pockets along the fluid metal surface. Water displaying is one such choice that could give valuable data on the conditions that may make air/gas/oxide entanglement during the filling procedure. One more alternative that has profoundly entered the current foundry situation yet may consistently be practical is the utilization of throwing recreation. The multifaceted nature of the filling procedure described by serious extent of non-consistency, instability, choppiness and free surface development calls for exploratory approval so as to have a genuine comprehension of the helpfulness of water models in reenacting the stream during constant throwing process and further more on the degree of programming capacity. Consequently it was proposed to contemplate the different parts of move through some chosen gating frame works usually utilized in foundries utilizing water models and further more reenact a similar utilizing programming to get some crucial comprehension of the capacities and constraints of the two choices.

Keywords: Casting; Metallurgical; Water Models.

Introduction

Nearly 70 million tons of cast components worth more than \$100 billion are produced annually for automobile, industrial machinery, municipal fittings and many other sectors, by over 33,300 foundries worldwide. An even larger number of companies are involved in designing, machining, testing and assembling cast components and in related activities such as tool making and material supply.

This vital industry is facing many challenges today. On one hand, metal casters have to meet the rising expectations of customers in terms of quality assurance, shorter lead time, smaller lot size and competitive pricing. On the other hand, foundries are severely outpaced by the rapid technological and management changes taking place in other manufacturing sectors. One example is the increasing use of NC machines for finishing operations, which re-

quire dimensionally stable castings with uniform surface hardness to prevent damage to cutting tools. Another example is the adoption of Just-In-Time philosophy by assemblers to reduce their inventory costs, which requires foundries to deliver on-time (often in terms of a particular date, time and factory gate number). Increasing pressure from regulatory bodies in terms of energy conservation, environment protection and operational safety is of additional concern. Many leading customers, particularly in the automobile sector, are therefore moving toward long-term strategic partnerships with a few capable foundries instead of short term cost-based purchasing agreements with a number of foundries as in the past.

This means that in order to survive, foundries have to offer dimensionally stable and sound castings (preferably with self-certification) and ensure reliable on-time delivery, more so in the case of export orders.

*Corresponding Author:

P. Sivaraman,
Assistant Professor, Mechanical Engineering, SKCT Coimbatore, India.
Email: sivaraman.p@skct.edu.in

Received: September 26, 2020

Accepted: February 25, 2021

Published: February 27, 2021

Citation: P. Sivaraman, T. Nithyanandhan, MK. Prabhu, B. Prasanna, G. Murali Krishna, S. Prassana Kumar, S N Kishore. Foundry Flow Studies Based on Water Model Gating System. *Int J Aeronautics Aerospace Res.* 2021;08(01):252-257. doi: <http://dx.doi.org/10.19070/2470-4415-2100032>

Copyright: P. Sivaraman©2020. This is an open-access article distributed under the terms of the Creative Commons Attribution License, which permits unrestricted use, distribution and reproduction in any medium, provided the original author and source are credited.

To achieve customer satisfaction without sacrificing profitability, foundry engineers need to precisely model and control the casting process to obtain the desired quality and optimize the yield without repetitive and time consuming shop floor trials. This is not easy, since casting is an inherently complex process. Flow, solidification and cooling of molten alloy in an intricately shaped cavity surrounded by heterogeneously packed mold material is complex enough; the range of geometric, material and process parameters involved in a foundry and the changing nature of customer requirements make each casting project a new challenge indeed.

The relatively nascent machining sector has grown far more rapidly in terms of processes, equipment, control, optimization and reliability, as evident by the large number of research publications, industry journals and general awareness among engineers. Casting has perhaps been considered a no-man's land between mechanical and metallurgical disciplines, aggravated by the difficulty in attracting and retaining qualified personnel in this area, both in industry and academia. Thus despite being a 5000 year old process, casting continues to be more of an art than science.

A wide variety of technological problems encountered in metal casting. These are largely due to differences in the physical properties and constitution of the alloys. Other significant differences include chemical activity and solubility for gases, mode of solidification, and contraction characteristics. These affect the problems of metal flow, mold stability, feeding, stress-free cooling and the structure and properties of the cast material. Individual techniques are thus required to meet conditions peculiar to the type of alloy. Once the essential foundry technique has been established the quality of a casting is influenced by numerous process variables.

Metal composition, for example, is often restricted by specification, although in the broader sense the needs of the casting process have influenced the ranges adopted in cast alloy specifications. This accounts for the frequent use of alloys close to eutectic composition, which show favorable characteristics with respect to fluidity, feeding and freedom from hot tearing. However, inoculation with very small amounts of certain elements can exercise potent effects both on foundry characteristics and casting structure, whilst control can also be exercised through molding material properties, melting practice, casting temperature and pouring speed. These variables, together with the techniques of gating, risering and chilling, can be used to control the entire pattern of cooling. This is the main key to the structure and quality of the finished casting.

Literature Review

Bjorklund E, [1] provided a basis for systematic analysis of dimensions of gating systems. Depending on the shape of the castings the approximate dimensions of the gating systems are established so as to permit the length of the runner and thickness of the ingates to be determined and an estimate to be made about the thickness of the ingates. On estimation of weight of the casting, density of the metal, pouring time, flow rate, coefficient of losses the total area of ingates is determined and the dimensions of the gating system are standardised.

Cuesta R, et al. [2] developed a mathematical theory that specifies the experimental conditions to perform water analogue tests as a simulation method of mold filling for ferrous and aluminium gravity castings. The theory was supported by the fluid-dynamic theory of analogy which establishes the possibility of extrapolating the results between two fluid experiments as long as certain non-dimensional numbers are equal in both the experiments. An impressive similitude between water and aluminium was found which validates his theory. The proposed theory was experimentally validated by means of the filling of a benchmark casting. Further, the relationship between velocities in the down sprue and entrapment phenomena in gravity castings was also investigated by making use of water experiments.

Elliot H E, et al. [3] discussed the influence of gating system on the degree of turbulence which occurred during the pouring of magnesium alloy castings. It was found that improper sprue design may lead to casting defects by the entrainment of gases in the metal stream. The degree of turbulence led to three defects namely, skins, blows and microporosity. The value of skim-gates as a method of controlling gating turbulence was shown. It was seen that turbulence could be reduced by a number of ways such as by reducing the pouring rate or by using non-aspirating sprues. Non-aspirating sprues used in conjunction with the liquid seal in the sprue base gave better quality than that was attained with the sprues of circular cross sections.

Flemings M C, et al. [4] illustrated the importance of a good gating design for aluminium castings. The functionality of every element of gating system was elaborated. Salient features involved in the design of elements of gating system were discussed systematically.

Fuoco R, et al. [5] discussed about the aspects of molten aluminium oxidation during mould pouring. General guidelines for designing the gating system for aluminium gravity castings are described and new gating concepts are discussed. These concepts were evaluated using water model technique applied to a thin vertical plate. Top pouring, side pouring, lateral pouring and bottom pouring systems were studied and the results are compared. It was proved that top pouring system exposes large quantities of surface to oxidation. Generation of most efficient gating concept was identified with and without the use of ceramic filters and also the horizontal and the vertical position of the runner.

Lin H J, et al. [6] studied the fluid flow along with heat transfer during filling of the horizontal and vertical castings. A suitable computational fluid dynamics technique, Solution Algorithm-fractional Volume of Fluid was employed. The proposed SOLA-VOF technique was able to handle free surface boundary conditions. The flow pattern and velocity profile of molten metal during the filling were calculated. Then the temperature variation of moving fluid and temperature change of the mould was predicted. The computed flow pattern was compared with experimental observation for consistency. It was reported that the temperatures of the molten metal and the mold did not show any change during filling of horizontal and vertical castings.

Masoumi M, et al. [7] studied the effect of gating design including on melt entry velocity by pouring molten metal of aluminium alloy A413 into a sand mould. A direct observation method was used with different gating designs to produce various flow pat-

terns. Real time Video camera was used to record these patterns. The experimental work was compared with an analysis performed by computer system. Experimental results indicate that gating system ratio, geometry and size of gate have great influence on the entry velocity of the molten metal into the mould. The experiment was done on a horizontally cast plate mould. It was also concluded that an increase in width of the gate for constant thickness, melt entry velocity decreases. Also in unpressurised gating systems deviation of melt flow from the centreline of the mould or incomplete gate filling tends to appear.

Masoumi M, et al. [8] reported the effect of gate geometry and size of gate on the flow pattern. The patterns were investigated by pouring molten metal of aluminum alloy A413 into a sand mold and it was recorded by a real time video camera. It was found out that increase in the width of the gate with a constant thickness resulted in three different patterns of mold filling. In non-pressurized gating systems, the deviation of melt flow from the centerline of the mold or incomplete gate filling appeared.

Dimensional analysis and Similitude

Dimensional analysis is an important tool to obtain maximum information from fewest experiments. It is a method for reducing the number and complexity of experimental variables which affect a physical phenomenon. In most of the experiments, to save time and money, tests are conducted on a geometrically scaled model, rather than on the full scale prototype. Dimensional analysis is a

powerful technique to properly scale the results between the model and prototype. However, dimensional analysis alone can never give complete solution of a problem. It usually permits considerable simplifications in investigating complex phenomena and may show the effect of particular variables, when the effects of some of the other variables are known. The underlying concept of dimensional analysis is the principle of similarity. Two systems are said to be physically similar with respect to certain specified physical quantities when the ratio of corresponding magnitudes of these quantities between the two systems is every where the same. Physical similarity is applicable whenever it is desired to compare the magnitudes of physical quantities in one situation with those in another. For any comparison between prototype and the model to be valid, the set of conditions associated with each other must be physically similar [9]. Physical similarity is a general term covering several different kinds of similarity. Two systems are said to be physically similar in respect to certain specified physical quantities when the ratio of corresponding magnitudes of these quantities between the two systems is every where the same. Fluid flow during mold filling can be characterized by a set of non-dimensional numbers. To obtain maximum similitude between the real casting and water model experiment, it is essential to maintain the boundary conditions as existing in the real casting and the mold scaling factors if any to be applied to the water models. This condition is met so long as certain non-dimensional numbers are the same in both the experiments. These numbers are extracted from the constitutive mathematical equations of the process, and involve thermo-physical data of the fluid, fluid dynamic variables such

Figure 1. Turbulence in the cavity.

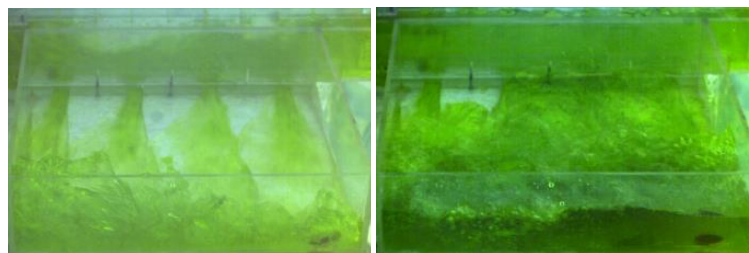

Shows two instances of mold filling where excessive amounts of turbulence are visualized during water analogue experiments.

as velocity and pressure and characteristic dimensions of the experiment. The characteristic numbers that govern the mold filling include are Weber number (We), Reynolds number (Re), Froude number (Fr) and Euler number (Eu) [10].

Design procedure of gating and runners

Design of gating system begins with the selection of the appropriate gating ratio for the alloy considered. The gating ratio chosen is 1:1.5:0.75, which is an unpressurized system. This gating ratio is commonly adopted for cast iron castings. A simple rectangular shaped cavity of size 381 X 381 X 60mm was taken up for study. The pouring basin is rectangular in cross section with dimensions 350 X 200 X 250mm. Thus it is ensured that volume of pouring basin is greater than that of cavity.

In the design of water models, pouring basin serves to provide the necessary head for fluid flow. In foundry practice, molten metal is poured from the ladle into the sprue as shown in fig 2. Here, the distance from the lip of the pouring ladle to the top of

the sprue is counted as the initial head. However, in water model studies, the initial head is compensated by the pouring basin.

The length of the runner is the same for all three runner combinations. It is chosen as 500mm, based on the representative lengths of runners used in nonferrous foundries. Along the length of the runner, nine holes, each of diameter 5 mm is drilled as shown in Figure 3. These holes serve to accommodate the piezometers. Piezometers are devices that give an indication of static pressure. Suitable markings are made on the tubes [11]. The height of water column in these tubes indicates the static pressure at a location. The tubes not only serve as a pressure indicator, but also act as vent holes. These openings along the length of the runner aid to minimize the excess pressure in the runner. A note of caution as regards to the use of piezometer tubes is that, these tubes must not protrude into the flow paths in the runner, causing an obstruction to flow. Any interruption to flow on account of these components, would hamper the smooth flow of the fluid and cause additional head losses because of the flow separation and mixing they induce. During design and subsequent manufacturing

stages, it must be borne that the lower end of the each tube must remain in flush with the bottom face of the top sheet of the runner. Fig 4 Shows the sprue base dimension[12].

Experimental Procedures

The experimental setup is made ready for a particular runner aspect ratio and ingate geometry. The camera is set on the tripod according to the focus and view required. The camera after being setup is connected to a computer using the Peripheral Connector Interface port. Using the MIDAS® interface software installed in the computer, a live stream is transmitted by the camera and can

be viewed on the screen. The stream is recorded and saved as a .avi video file. The procedure is repeated to facilitate recording of experiments in all required angles and views for all models. The picture files are then analysed with each frame of the videos being interpreted scientifically as shown in Fig 7.

Fig 8 shows three aspect ratio with which the rectangular gate is compared with. The final graph in fig 8 shows that all the four ingates are almost having the same discharge rate with small difference with ingate 2 as the runner is wide and shallow. The back flow is more in this runner because of its shallowness. Hence ingate 2 (G2) is having a high discharge rate. In general it can be said that the almost uniform discharge rate can be seen in fig 8.

Figure 2. Schematic of sprue.

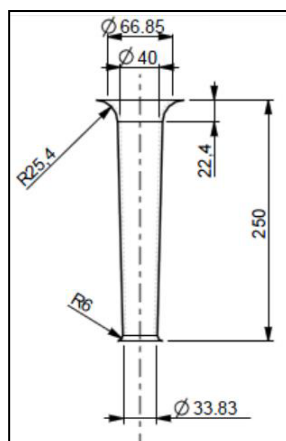

Figure 3. Deep and narrow runner.

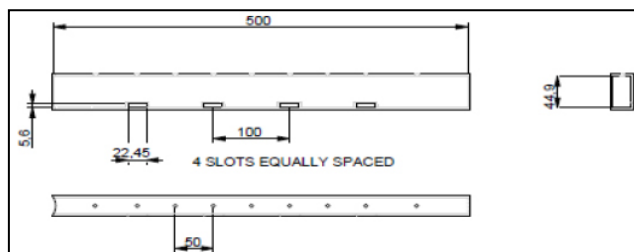

Figure 4. Sprue.

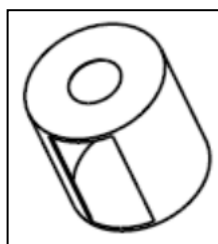
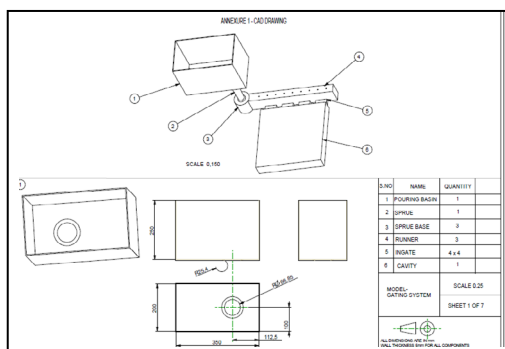

Figure 5. Complete gating System.



shows the complete design of the gating system model

Figure 6. Experimental image of gating system.



shows the experimental image of the gating system.

Figure 7. Experimental view.



Figure 8. Graph based on results.

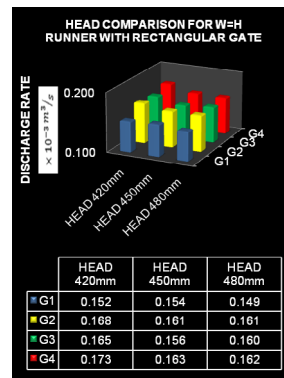

Conclusion

In this work, the principles involved in the design of gating systems and that of dimensional analysis were employed to fabricate water models of gating systems made out of transparent acrylic. The hydraulics of gating system was studied and the results were correlated to that of real time casting. The following are the conclusions drawn out of this work.

With rectangular ingates and $W = 0.5H$ runner combination, the filling is more uniform and is considered best for the alloy and cavity geometry considered in this study.

Also the flow through the gates G1 and G2 tend to deviate from the centre path because of lower velocities and vorticity transport from the runners.

Comparing the computer simulation with the flow visualization videos, aspects like intense churning action at the bottom of the sprue base along with intense splashing all over the sprue base and runner were not captured by the simulation. Sparse flow at the middle of the runner is one of the striking similarities observed. In the runner region, the flow stream appears to be calm

and straight in the simulation, which contradicts real time video detail.

Finally, it was understood that flow visualization using water models in conjunction with flow measurements could reveal interesting and intricate information concerning the flow characteristics of a particular runner gating combination that could in turn give an indication of the suitability of a particular gating design for the alloy-casting.

References

- [1]. Bjorklund E. Calculating ingate dimensions for gray iron castings. AFS Transactions. 1962;70:193-205.
- [2]. Cuesta R, Maroto JA, Morinigo D, De Castro I, Mozo D. Water Analogue Experiments as an Accurate Simulation Method of the Filling of Aluminum Castings. Transactions-American Foundrymen Society. 2006;114:137.
- [3]. Elliott HE, Mezzoff JG. Effect of gating design on metal flow conditions in the casting of magnesium alloys. AFS Trans. 1948;56:223-45.
- [4]. Flemings MC, Taylor HF. Gating Aluminium Castings. Transactions of American Foundrymen Society. 1960; 72-78.
- [5]. Fuoco R, Cabezas CS, Correa ER, Bastos MA. Study on Gating System Design for Aluminum Gravity Castings Using Water Models. 1st International Conference on Gating, Filling and Feeding of Aluminum Castings. 65-86.
- [6]. Lin HJ, Hwang WS. Combined fluid flow and heat transfer analysis for the filling of casting. Modeling and Control of Casting and Welding Processes. IV. 1988;487-511.

- [7]. Masoumi M, Boutorabi MA, Hedjazi J. Effect of Gating Design on Melt Entry Velocity. *Transactions of American Foundrymen Society*. 2008; 47-60.
- [8]. Masoumi MH, Hu H, Hedjazi J, Boutorabi M. Effect of gating design on mold filling. *Transactions of the American Foundry Society*, Vol. 113. 2005 Apr;113:185-96.
- [9]. Mirbagheri SM, Dadashzadeh M, Serajzadeh S, Taheri AK, Davami P. Modeling the effect of mould wall roughness on the melt flow simulation in casting process. *Applied Mathematical Modelling*. 2004 Nov 1;28(11):933-56.
- [10]. Ravi B. Casting simulation and optimisation: benefits, bottlenecks and best practices. *Indian Foundry Journal*. 2008 Jan;54(1):47.
- [11]. Stoehr RA, Wang WS. Combined Effects of Heat Transfer and Fluid Flow During the Filling of Castings. *Transactions of American Foundrymen Society*.
- [12]. Sivaraman P. Experimental studies on flow of molten metal through gating systems using water models. *International Journal of Research in IT, Management and Engineering*. 2015 May;5(5):42-9.